

EE / CprE / SE 492 Weekly Report

October 17 - October 31, 2024

sddec24-16

Designing a Smart Plant Nurturing System Enabled by IoT Technology

Faculty Advisor / Client: Md Maruf Ahamed

Team Members:

- Tejal Devshetwar - Frontend
- Holden Brown - Frontend/backend
- Blake Hardy - Backend
- Cameron Jones - Backend
- Cayden Kelley - Hardware
- Chase O'Connell - Hardware

Summary of Work:

Within the past week, our group made incremental progress on both the hardware and software. In terms of hardware, we have finalized our selection of sensors for the device. This leaves the enclosure and PCB as the final components still remaining for our device. As testing for data is difficult without consistent power, we are focusing on the PCB power circuit development next. In terms of software, we continued to work on getting full loop communication through HTTP requests sent from the Arduino. Due to the security / login of the school network, we are continuing to have difficulties. We also need to update the board firmware to work with the new sensors we have ordered as well as the pumps that we already have. For app development, we will be using Glitch for processing and MongoDB for data storage. Currently we are working on setting up these tools to work together and with our device.

Work Period Accomplishments:

- Ordered the final sensors we will use in our device.
 - NPK, pH, Moisture, Temperature: [Link](#)
 - PAR Light Sensor: [Link](#)
- Continued testing on Arduino for HTTP requests
- Setup for backend tools
 - Glitch - Created a team account
 - MongoDB - Data storage
 - Mongoose for data communication
- Began PCB schematics for device power
 - Buck Converter: Using reference design implementation for external capacitors and resistors needed to use the chip correctly.
 - Arduino slot: The Arduino will be directly soldered to the board for power distribution. Some signals may potentially be added for the relays to be used.

- Connectors: Power connectors for the pump system, NPK sensor, and PAR sensor are included.

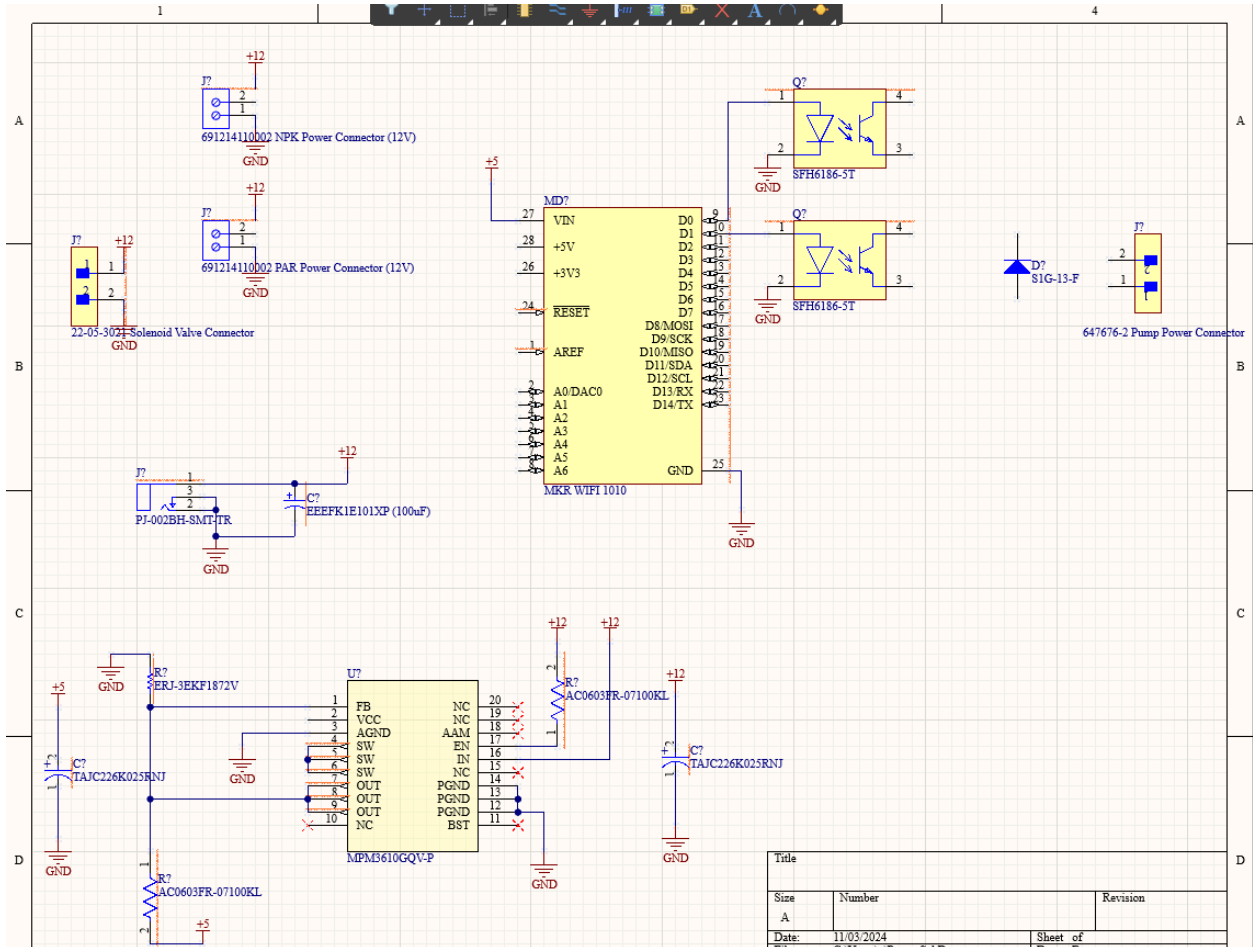

Plans for Coming Week + Action Items:

- Holden Brown - Update database to take in PAR data. Adjust UI to encompass when the user only has one plant. Create a full-screen option for the sensor data graph.
- Tejal Devshetwar - Work with Holden on his approach to set up communication other than websockets. Use the endpoints of the database to establish communication. If that does not work then decide to use websockets.
- Blake Hardy - Finish working on HTTP functionality on the arduino, get new sensors programmed and integrated into the system. Need to refactor the arduino code a bit and will look into getting existing code working with freeRTOS. Will look into implementing power saving functionality as the device becomes a more complete and coherent system. Will look into additional features like error handling and asking users for correction if necessary.

- Cameron Jones - Work further with Blake to get the arduino communicating with the server. Perform research to see if websockets are still viable for moment to moment communication
- Cayden Kelley - Order remaining components, help Chase with PCB layout, look at enclosure options.
- Chase O'Connell - Complete schematics and layout of PCB in Altium including all components.

Pending Issues:

- Tejal Devshetwar
 - No issues
- Holden Brown
 - No issues
- Blake Hardy
 - Some formatting issues and a misunderstanding of some aspects of http requests. I think they are resolved but I still need to test to make sure. Might need to have holden make a few changes to the server endpoints as well to accommodate new sensors.
- Cameron Jones
 - Still having issues with communicating with the server due to the server using https rather than http meaning additional steps will have to be taken to circumvent the additional security.
- Cayden Kelley
 - No issues
- Chase O'Connell
 - No issues.

Individual Contributions:

Team Member	Contribution	Weekly Hours	Total Hours
Tejal Devshetwar	Got everything working on my laptop including Glitch, and the app. Initially dependencies caused errors but now everything is working.	1.5	28.5
Holden Brown	Met with Tejal and went over the data flow through our database. Made specifications for the database so teammates can access and use it more easily.	1	52 .9

Blake Hardy	Attempted to get the arduino to make HTTP requests, but was prevented by the school network and formatting difficulties. I looked into the problem a bit more later and I think I have it right. Will confirm the next time I'm in lab.	5	51
Cameron Jones	Worked with Blake to try and get HTTP requests sent to the server.	3	43.6
Cayden Kelley	Looked at alternative pump options due to low head pressure of current pumps, opted for solenoid valve instead of two pumps, worked with Chase on PCB schematics.	5	63.6
Chase O'Connell	Ordered final sensors to use in our device (PAR light sensor and NPK with pH, moisture, and temperature). Designing PCB schematics + finalizing board component selection.	5.5	45